



minipack® - torre
Packaging machines and systems

FM76 EVO

TROLLEY MANUAL HEAT-SHRINK - FULL OPTIONAL - PACKAGING PLATE
540X390 MM



DESCRIPTION

Minipack@-torre always pursues its pioneering spirit. Indeed, the company was set up more than 40 years ago, precisely thanks to the idea of chamber machines, which was patented in 1976. But ideas cannot stop. Today, the company is launching a new line which is the result of years of research and development and represents the synthesis of the **minipack@-torre** compact machines: easy to use, sturdy and reliable.

TECHNICAL FEATURES

Electrical power supply	V	200/230
-------------------------	---	---------



Phase	ph	1
Maximum power installed	kW	3.15
Hourly output	pcs/h	0-300
Available dimensions of the sealing bars	mm	540x390
MAX product size	mm	500x380x200
MAX Reel Dimensions (diameter)	mm	250
MAX Reel Strip Dimensions (width)	mm	600
Work Surface Height	mm	940
Machine dimensions with the lid open	mm	1260x810x1400
Machine dimensions with the lid closed	mm	1260x810x1190
Weight (Net/Gross)	Kg	126/150

minipack@torre shall not be held liable for typos or printing errors in this catalogue. It also reserves the right to make changes to the specified features without prior notice. All trademarks are property of their respective owners and are hereby acknowledged.

TECHNICAL DRAWING

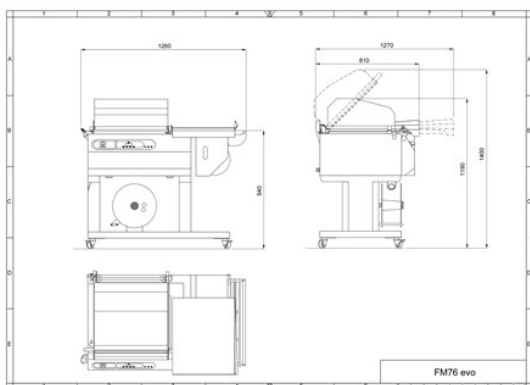

TECHNICAL SOLUTIONS

- **High-performance steel resistors:** shrinking time cut by 50% and heating time cut by 60%
- **Soft Shrink fan speed adjustment:** perfect heat-shrinking also on very light or flexible products. Sealed areas do not open. Extremely quiet. Exclusive patent
- **Comfort Zone Fan Stop:** the fan stop is a “green” solution that allows to save 20% more energy and provides greater operator comfort during packaging, since the fan stops when the chamber opens
- **New latest-generation board:** quality components. 4-digit display
- **Waste rewinder:** productivity up by 20%



minipack® - torre
Packaging machines and systems

- **Sealing bar cooling:** increased productivity and improved sealing

OPTIONAL FEATURES

- Stainless steel packaging plate
- Smoke intake
- Blowing unit
- High hood 300 mm
- Film opening sheet metal
- 2nd reel support
- 2nd tabletop reel support