

Reisopack[®]

Automatic strapping
machine side sealing with lance

2100

Strapping technologies

**Straps vertically
the loads quickly
and reliable**



Automatic strapping machine side sealing with lance

High performance automatic strapping machine. Very fast. Maximum reliability.

- Designed and manufactured using highest quality components.
- Aluminium head set and tension roller treated ensures long life of the machine.
- Tension electronically adjustable through a magnetic clutch to get the strongest tension without any physical effort.
- Electronic control of the tension, heating, cutting and length of the strap.
- Adjustment of the cooling after sealing to get better sealing quality, especially for hard packages (wood, iron, etc).

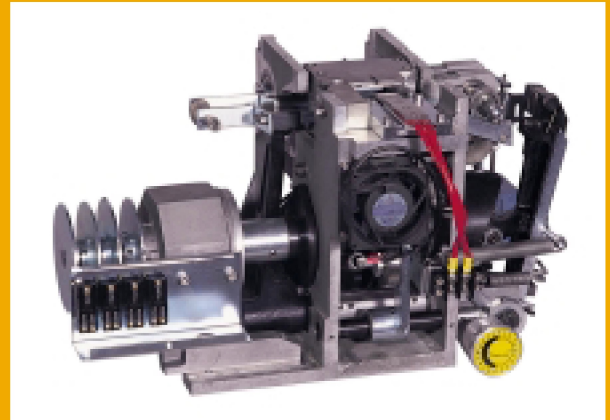

OPTIONS:

- Available in a range of different dimensions of arch.
- Double magazine for big arches.
- Mouvement of the all machine to look for the pallet.
- Machine prepared to be putted in an automatic line.

Automatic strapping machine side sealing with lance



The lance puts the strap in the gap of the pallet.

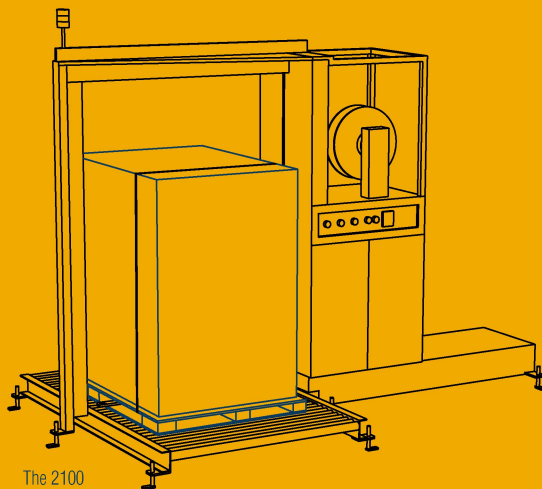

The 2100 is prepared to be putted in an automatic line.

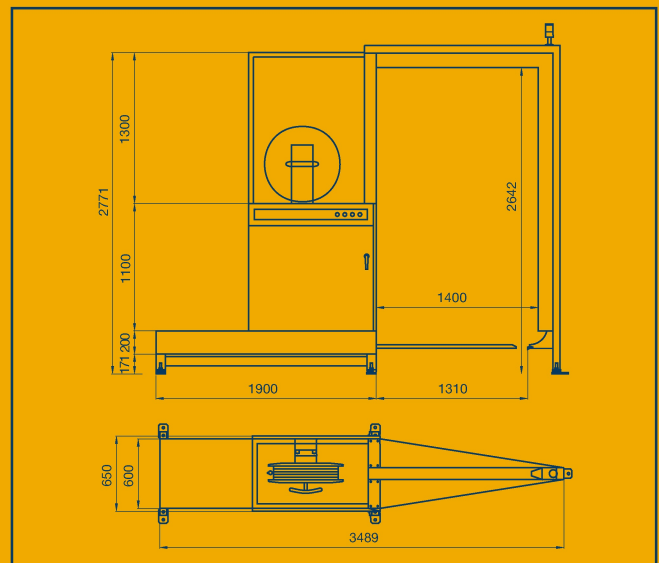

CHARACTERISTICS

VOLTAGE: 220V / 380 V - 50 / 60 Hz. 3 phase.

ELECTRIC CONSUMPTION: 1 Kw.

APROX. PRODUCTION: 20 pallets / hour.

PACKAGING DIMENSIONS: 1 package (200 Kg.).

210 X 70 X 240 cm.

TECHNICAL SPECIFICATIONS

STRAP WIDTH: 12-15,5 mm.

STRAP THICKNESS: 0,50-0,85 mm.

HEATING SYSTEM: Heating temperature and cooling time adjustable.