

GEM 52

NEW



LAST GENERATION

GEM 52

[It]
DESCRIZIONE

Nastratrice per scatole a formato fisso.

La serie Gem segue una filosofia costruttiva modulare, consentendo uniformità e versatilità dei pezzi di ricambio.

[En]
DESCRIPTION

Uniform case sealer.

The GEM series is based on a modular construction concept for uniformity and adaptability of spare parts.

[Fr]
DESCRIPTION

Machine a fermer les caisses americaines monoformat.

La série Gem adopte une conception modulaire qui permet d'utiliser les pièces standard.

[De]
BESCHREIBUNG

Kartonschachtel-verschliessmaschine für gleichbleibende formate.

Die Serie GEM folgt einer Modularbauweise und ermöglicht damit Gleichförmigkeit und Vielseitigkeit bei den Ersatzteilen.

[Es]
DESCRIPCIÓN

Precintadora para cajas de formato fijo.

La serie Gem sigue un diseño modular, lo que permite la consistencia y versatilidad.

DATI TECNICI:

TECHNICAL DATA:

DONNÉES TECHNIQUES:

TECHNISCHE DATEN:

FICHA TÉCNICA:

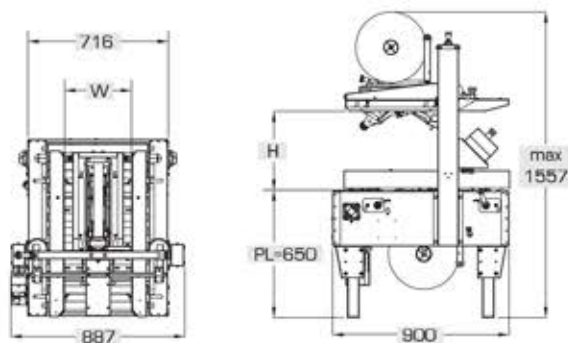

misure/measures/mesures/maßnahmen/medidas: mm

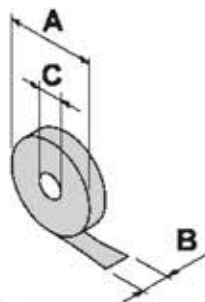

A	MAX 360 mm (14")
B	25+75 mm (1"+3")
C	76 mm (3")

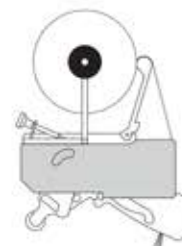

- Teste Nastranti:
- Taping Heads:
- Têtes de pose:
- Klebeköpfe:
- Cabezal de precinto:

T21-T21,5-T22-T23
T32-T33
TH22-TH23

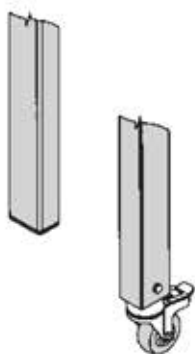

- Gambe con piedino fisso
- Legs with fixed foot
- Pieds à base fixe
- Standbeine mit fixem Fuß
- Patas con pie fijo

OPTIONAL:

- Gambe con ruote
- Legs with wheels
- Pieds à roulettes
- Standbeine mit Rädern
- Patas con ruedas

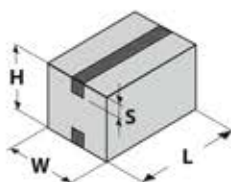

	MIN	MAX
L	150 mm	∞
W	100 mm	500 mm
H	100 mm	500 mm
S	25 mm	75 mm

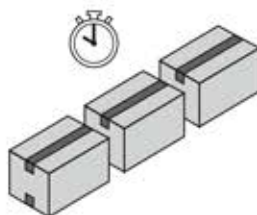

- Produzione media:
- Average production:
- Production moyenne:
- Durchschnittliche Produktion:
- Producción promedio:

800 %

- Velocità di trasferimento scatola:
- Box transfer speed:
- Vitesse de transfert de la boîte:
- Transportgeschwindigkeit der Kartons:
- Velocidad de desplazamiento caja:

~22 mt/min



- Alimentazione:
- Power supply:
- Alimentation:
- Speisung:
- Alimentación:

3 / ±

- Potenza installata:
- Installed power:
- Puissance installée:
- Eingerichtete Leistung:
- Potencia instalada:

0,25 kW

- Protezione elettrica:
- Electrical protection:
- Protection électrique:
- Stromschutz:
- Protección eléctrica:

IP54



- Temperatura di utilizzo:
- Temperature of use:
- Température d'utilisation:
- Betriebstemperatur:
- Temperatura de uso:

	MIN	MAX
°C	+5	+35
°F	+41	+95



- Peso:
- Weight:
- Poids:
- Gewicht:
- Peso:

112 Kg

Distributed by

Idépack Verpakkingsmachines B.V.
Zeilmaker 8
NL-3861 SM Nijkerk
Tel. +31(0)33-299 00 08
www.idepack.com info@idepack.com

COMARME

COMARME S.r.l. a socio unico

sede operativa (factory)
Via dei Trivulzio, 5/6 - 20081 CASSINETTA DI LUGAGNANO (MI) - ITALY
Tel. +39 02 9422002 - Fax +39 02 9422096

e-mail: info@comarmesrl.com - website: www.comarmesrl.com



- NASTRATRICE SEMIAUTOMATICA PER SCATOLE A FORMATO FISSO IN ACCIAIO INOX
- SEMIAUTOMATIC TAPING MACHINE FOR FIXED-FORMAT BOXES IN STAINLESS STEEL
- MACHINE SEMI-AUTOMATIQUE POUR BOITE MONO - FORMAT EN ACIER INOXYDABLE
- HALBAUTOMATISCHE KLEBEMASCHINE FÜR SCHACHTELN MIT GLEICHEN FORMAT IN EDELSTAHL
- PRECINTADORA SEMIAUTOMATICA PARA CAJAS DE FORMATO FIJO IN ACERO INOX

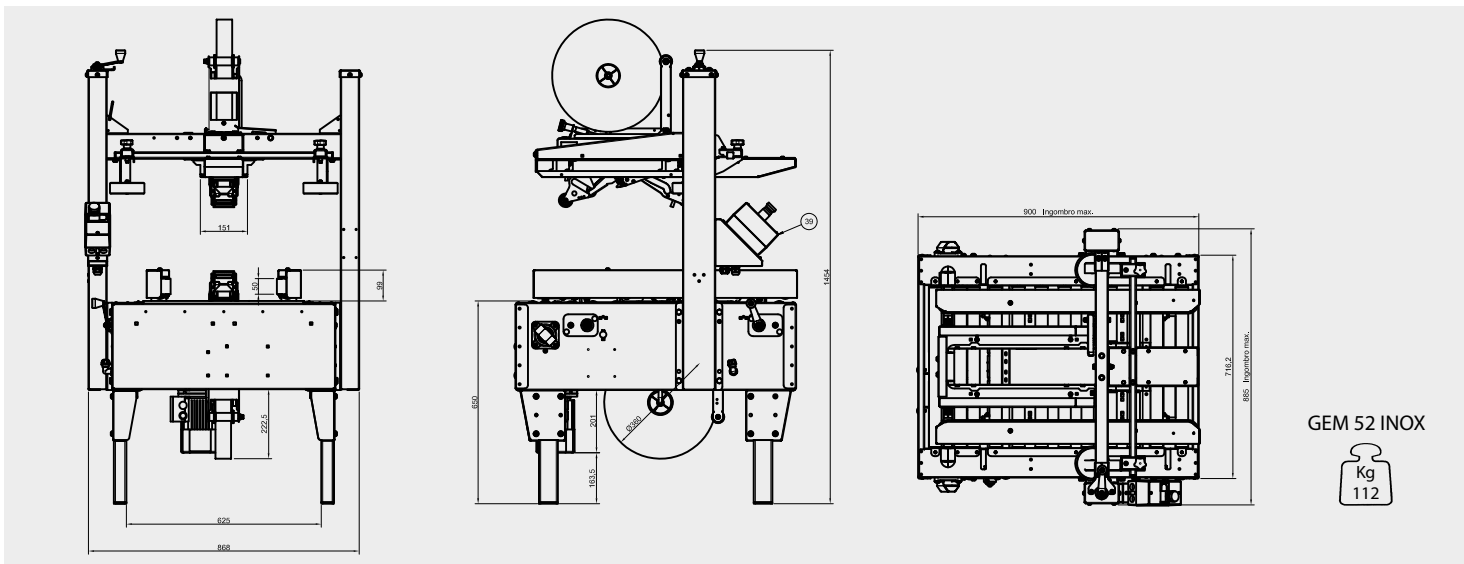

GEM 52 INOX

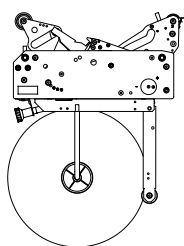

- Teste Nastranti:
- Taping Heads:
- Têtes de pose:
- Klebeköpfe:
- Cabezal de precinto:

T22 - T23 - Standars
T21 - T21,5 - T22 - T23 - T32 - T33 - Optional

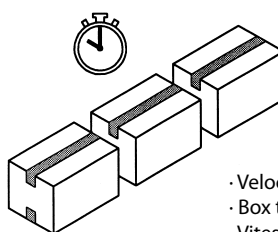

- Produzione media: 800 scatole/ora
- Production moyenne: 800 boîtes/heure
- Producción promedio: 800 cajas/hora
- Average production: 800 boxes/hour
- Durchschnittliche Produktion: 800 Kartons/St

- Velocità di trasferimento scatola: ~22 mt/min
- Box transfer speed: ~22 mt/min
- Vitesse de transfert de la boîte: ~22 mt/min
- Transportgeschwindigkeit der Kartons: ~22 mt/min
- Velocidad de desplazamiento caja: ~22 mt/min

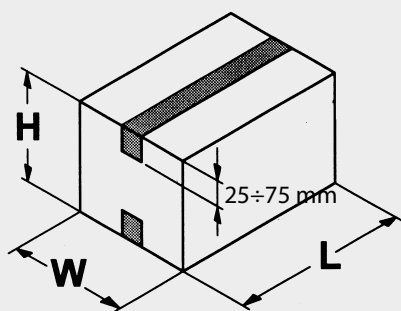

GEM 52 INOX		
	MIN	MAX
L	150 mm	∞
W	100 mm	500 mm
H	100 mm	500 mm



- Gambe con piedino fisso in acciaio inox
- Legs with fixed foot in stainless steel
- Pieds à base fixe en acier inoxydable
- Standbeine mit fixem Fuß in Edelstahl
- Patas con pie fijo in acero inox

OPTIONAL:

- Gambe con ruote
- Legs with wheels
- Pieds à roulettes
- Standbeine mit Rädern
- Patas con ruedas

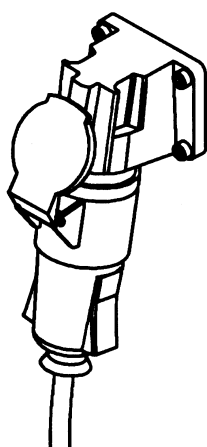
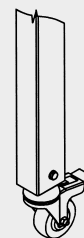

- Alimentazione: Trifase/Monofase
- Power supply: Three-phase/Single-phase
- Alimentation: Triphasée/Monophasée
- Speisung: Dreiphasig/Einphasig
- Alimentación: Trifásica/Monofásica

- Potenza installata: 0,25 Kw
- Installed power: 0,25 Kw
- Puissance installée: 0,25 Kw
- Eingerichtete Leistung: 0,25 Kw
- Potencia instalada: 0,25 Kw

- Protezione elettrica: IP54
- Electrical protection: IP54
- Protection électrique: IP54
- Stromschutz: IP54
- Protección eléctrica: IP54

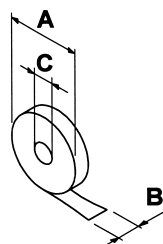

GEM 52 INOX	
A	MAX 360 mm
B	25 ÷ 75 mm
C	76 mm

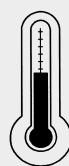

MAX
+35°C/95°F

MIN
+5°C/41°F

- Temperatura di utilizzo:
- Temperature of use:
- Température d'utilisation:
- Betriebstemperatur:
- Temperatura de uso:

Distributed by

Idépack Verpakingsmachines B.V.
Zeilmaker 8
NL-3861 SM Nijkerk
Tel. +31(0)33-299 00 08
www.idepack.com info@idepack.com

COMARME

COMARME S.r.l. a socio unico

sede operativa (factory)
Quartiere Mirabella snc, 20081 Abbiategrasso (MI) - ITALY
Tel. +39 02 9422002 - Fax +39 02 9422096

e-mail: info@comarmesrl.com - website: www.comarmesrl.com