

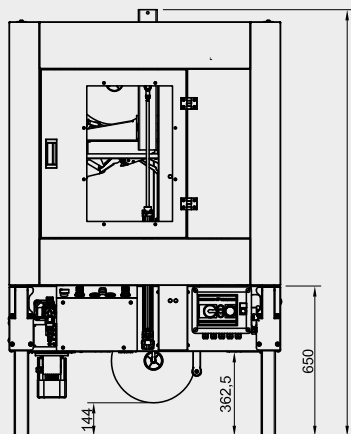

- NASTRATRICE AUTOMATICA AUTODIMENSIONANTE
- AUTOMATIC SELF-DIMENSIONING TAPING MACHINE
- FERMEUSE AUTORÉGLABLE POUR CARTONS MULTI-FORMAT
- UTOMATISCHE VERKLEBEMASCHINE FÜR KARTONS MIT WECHSELNDEN FORMATEN
- PRECINTADORA AUTOMATICA CON DIMENSIONAMIENTO AUTOMÁTICO DE CAJAS DE FORMATO VARIABLE

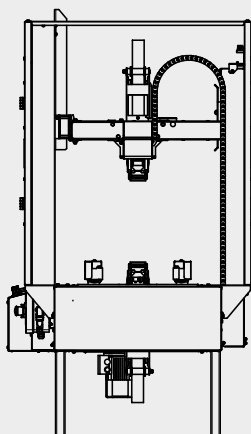

GEM X520 = 1782
GEM X670 = 1899
GEM X820 = 2199



GEM X520 = 1064
GEM X670 = 1214
GEM X820 = 1364

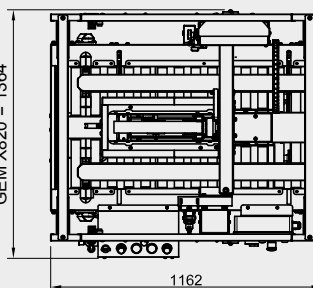

GEM X520



GEM X670



GEM X820



- Alimentazione pneumatica
- Pneumatic power supply
- Alimentation pneumatique
- Druckluftspeisung
- Alimentación neumática

6 bar

- Consumo aria per ciclo scatola
- Air consumption cycle box
- Consommation d'air par cycle boîtes
- Luftverbrauch pro Kartonzyklus
- Consumo de aire por ciclo caja

GEMX520 = 6,5 nl
GEMX670 = 8,5 nl
GEMX820 = 11 nl

- Produzione media: 300/500 scatole/ora
- Production moyenne: 300/500 boîtes/heure
- Producción promedio: 300/500 cajas/hora
- Average production: 300/500 boxes/hour
- Durchschnittliche Produktion: 300/500 Kartons/Std

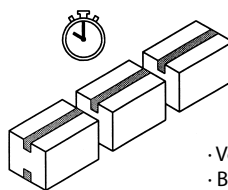

- Velocità di trasferimento scatola: ~22 mt/min
- Box transfer speed: ~22 mt/min
- Vitesse de transfert de la boîte: ~22 mt/min
- Transportgeschwindigkeit der Kartons: ~22 mt/min
- Velocidad de desplazamiento caja: ~22 mt/min

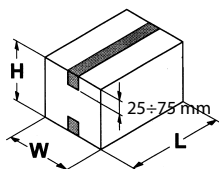

GEM X520

	MIN	MAX
L	200 mm	∞
W	100 mm	520 mm
H	100 mm	520 mm

GEM X820

	MIN	MAX
L	200 mm	∞
W	100 mm	820 mm
H	120 mm	820 mm

GEM X670

	MIN	MAX
L	200 mm	∞
W	100 mm	670 mm
H	120 mm	670 mm



- Alimentazione: Trifase/Monofase
- Power supply: Three-phase/Single-phase
- Alimentation: Triphasée/Monophasée
- Speisung: Dreiphasig/Einphasig
- Alimentación: Trifásica/Monofásica

- Potenza installata: 0,23 Kw
- Installed power: 0,23 Kw
- Puissance installée: 0,23 Kw
- Eingerichtete Leistung: 0,23 Kw
- Potencia instalada: 0,23 Kw
- Protezione elettrica: IP54
- Electrical protection: IP54
- Protection électrique: IP54
- Stromschutz: IP54
- Protección eléctrica: IP54

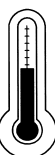

MAX
+35°C/95°F

MIN
+5°C/41°F

- Temperatura di utilizzo:
- Temperature of use:
- Température d'utilisation:
- Betriebstemperatur:
- Temperatura de uso:

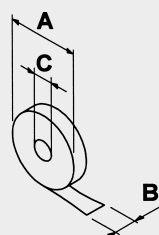

A	MAX 360 mm
B	25 ÷ 75 mm
C	76 mm

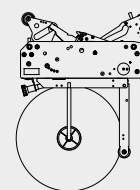

- Teste Nastranti:
 - Taping Heads:
 - Têtes de pose:
 - Klebeköpfe:
 - Cabezal de precinto:
- T22 - T23 / T32 - T33 (standard)

T21 - T21,5 (optional)
con-with-avec-mit-con Kit adaptor 2

ITALY ACCESSORI:

- Kit ruote
- Centratore / cadenziatore automatico in ingresso mod. DAC
- Kit memoria altezza scatola
- Kit rulli pressatori pneumatici superiori
- Kit Rottura Fine Nastro – RFN
- Kit lettura cartoni leggeri
- Kit esclusione nastratura superiore
- Kit esclusione nastratura inferiore
- Versione per scatole ad altezza ridotta
- Rulliere ingresso / uscita

ENGLAND ACCESSORIES:

- Caster wheels
- Automatic centering device DAC model
- Memory switch
- Pneumatic top presser rollers device
- Tape tearing & end indicator device
- Light boxes sealing set
- Upper taping disabling set
- Lower taping disabling set
- Low boxes sealing
- Infeed & outfeed conveyors

FRANCE ACCESSOIRES:

- Kit roues
- Centreur automatique-DAC en entrée
- Kit mémoire hauteurs de caisses
- Kit rouleaux presseurs pneumatiques supérieurs
- Kit rupture d'adhésif et fin de rouleau
- Kit lecture caisses légères
- Kit d'exclusion pose adhésif supérieur
- Kit exclusion pose adhésif inférieur
- Version pour hauteur réduite des caisses
- Convoyeur en entrée et sortie

GERMANY ZUBEHÖR:

- Einlauf-Rollentisch mit Zentrierung - DAC
- Kit fixe Kartonhöhe für Kartonserien
- Kit pneumatische obere Andruckrollen
- Kit Überwachung Bandriss/ Bandende - RFN
- Kit für leichte Kartons
- Kit Transit ohne Verklebung oben
- Kit Transit ohne Verklebung unten
- Ausführung für niedrige Kartons
- Einlauf-/Auslauf Rollenbahnen

SPAIN ACCESORIOS:

- Kit de ruedas
- Dispositivo de centrado automatico de entrada - DAC
- Kit de memoria altura de caja
- Kit de rodillo prensor neumático superior
- Kit de rotura fin de cinta - RFN
- Kit de lectura cartón ligero
- Kit de exclusión precintado superior
- Kit de exclusión de precintado inferior
- Versión para cajas con altura reducida
- Transportadores de rodillos de entrada / salida

Distributed by

Idépack Verpakkingsmachines B.V.
Zeilmaker 8
NL-3861 SM Nijkerk
Tel. +31(0)33-299 00 08
www.idepack.com info@idepack.com

COMARME

COMARME S.r.l. a socio unico

sede operativa (factory)
Quartiere Mirabella snc, 20081 Abbiategrasso (MI) - ITALY
Tel. +39 02 9422002 - Fax +39 02 9422096

e-mail: info@comarmesrl.com - website: www.comarmesrl.com