



SIAT

M. J. MAILLIS GROUP

SR20 Semi Automatic Carton Sealers



STRONG DESIGN
Solid H frame structure



EASY MAINTENANCE
Fast-removable top taping head

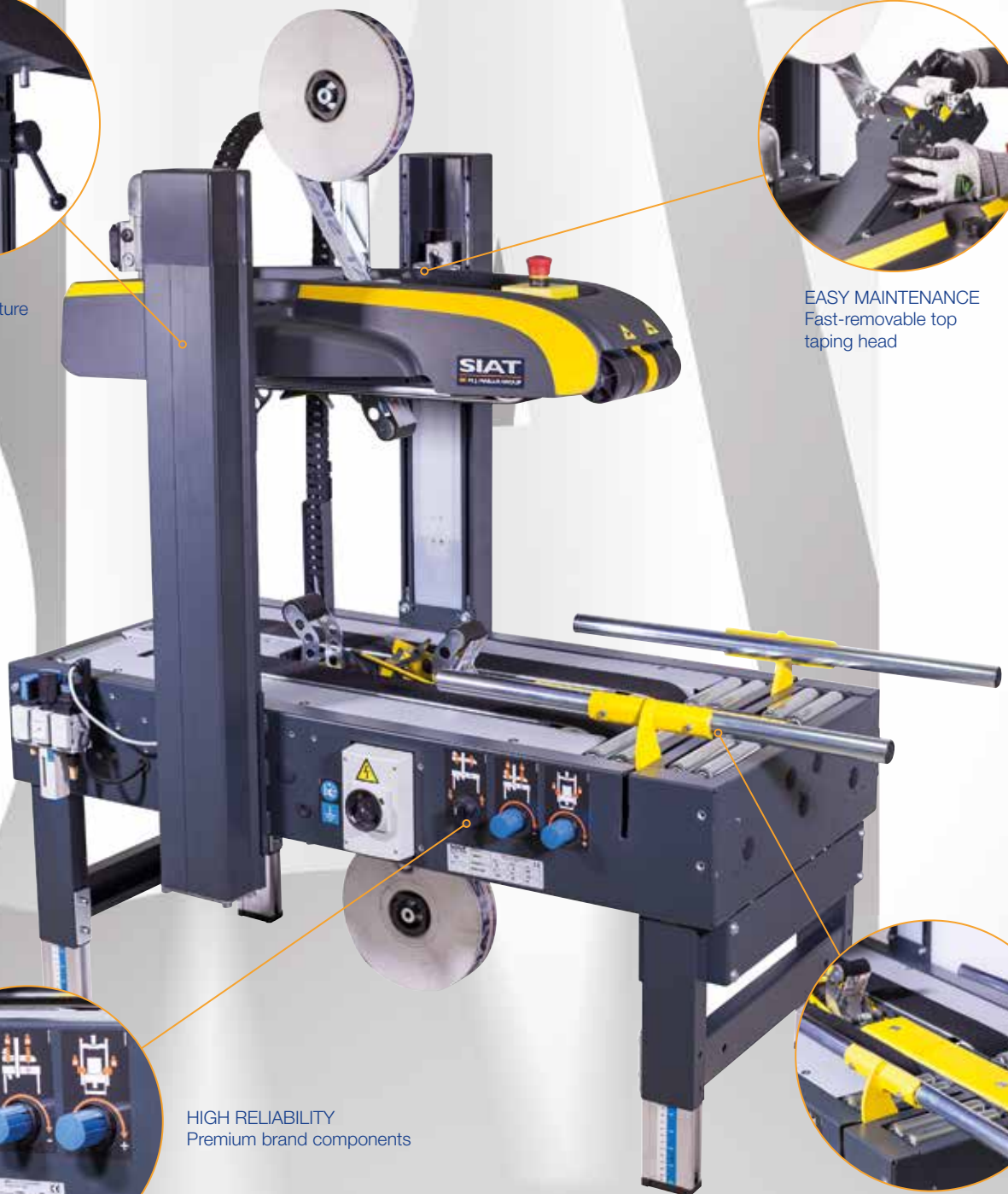

HIGH RELIABILITY
Premium brand components



PERFECT CONTROL
Thanks to the 4 belts and the random adjustment on the box size



The semi-automatic case sealer **SR20** represents the ideal solution when your packaging line processes boxes with different dimension. Thanks to the 4 belts box control, the sealing process is always guaranteed without jams, also in case of overstuffed and empty boxes. The pneumatic system allows a fast adaptation to a large range of box dimensions. The robust dual masts frame and the branded components make the **SR20** ready for round-the-clock applications. The historical SIAT machines reliability is always guaranteed! The fast-removable taping head, the easy access to the motors and the clear cable management allow an efficient check of the machine, facilitating maintenance operations.



> **Machine dimensions**
Dimensioni macchina
Machinmessungen
Dimensions de la machine
Dimensiones de máquina

Packaging size / weight			LxWxH
> SR20	170	190	130x78x115

> **SR20**

	Min.	Max
L	1240	-
L1	1395	-
W	740	-
H	1265	1605
cbh	485	825
AS 77	cbh +110	cbh +110
AS 80	cbh +160	cbh +160

> **Box dimensions**
Dimensioni delle scatole
Kartonabmessungen
Dimensions des boîtes
Dimensiones de cajas

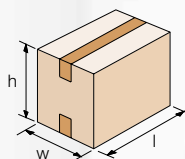

> **SR20**

	K11R std. / K12R on demand	
	Min.	Max
l	150	∞
w*	140 / 170	500
h	100	500

> **Production capacity**
Capacità di produzione
Produktionskapazität
Capacité de production
Capacidad de producción

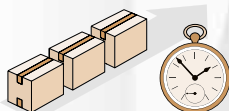

> **SR20**

	Bph
Max pcs.*	900

* Always based on shorter manageable box

> **Air consumption**
Consumo aria
Druckluftverbrauch
Consommation air comprimé
Consumo de arie

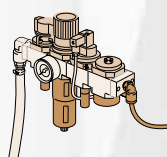

> **SR20**

	NL.
Cycle	9

from 5,5 bar to 7 bar

> **Standard voltage**
Vitaggio standard
Standardspannung
Tension standard
Voltaje estándar

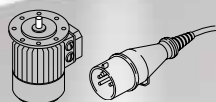

> **SR20**

380/415V - 50Hz - 3P	
Amps	1,08
Power kW	0,26
Phase	3Ph + N + PE

> **SR20**

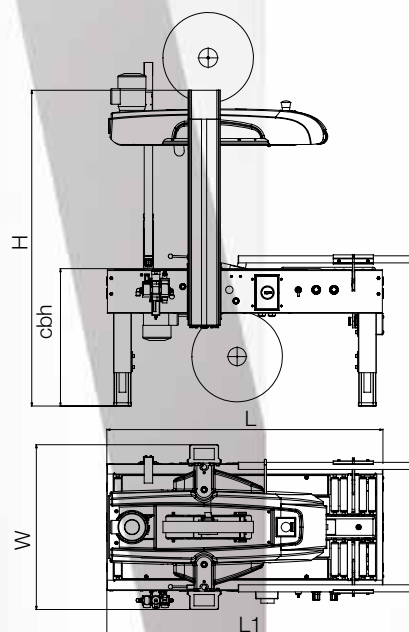

> **Taping units**
Unità nastranti
Verschliesseinheiten
Unités enrubanneuses
Unidades de precinto

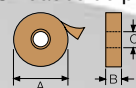

	K11R/ K12R
	mm
A	410 Max
B	50 / 75
C	76

> **Optionals**
Accessori
Zubehör
Accessories
Accesorios

> **AS80**
Higher legs
Set gambe più alte
Höhere Stützen
Pieds plus hauts
Patas más altas



> **AS77**
Casters
Set ruote
Rädchen
Roulettes
Ruedas

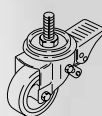

> **RG**
Roller conveyor
Piani a rulli
Rollenbahnen
Plans à rouleaux
Rodillos libres



> **GTL - GTR**
Extendable conveyor
Rulliera estensibile
Ausziehbare rollenbahnen
Convoyeur extensible
Rodillos extensibles

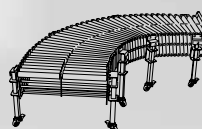

> **K-125 / K-250**
Inkjet printer
Stampante ad inchiostro
Tintenstrahldrucker
Marqueur à jet d'encre
Impresora de inyección de tinta

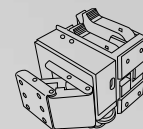

SIAT

MAILLIS

SR46 Semi-Automatic Carton Sealers

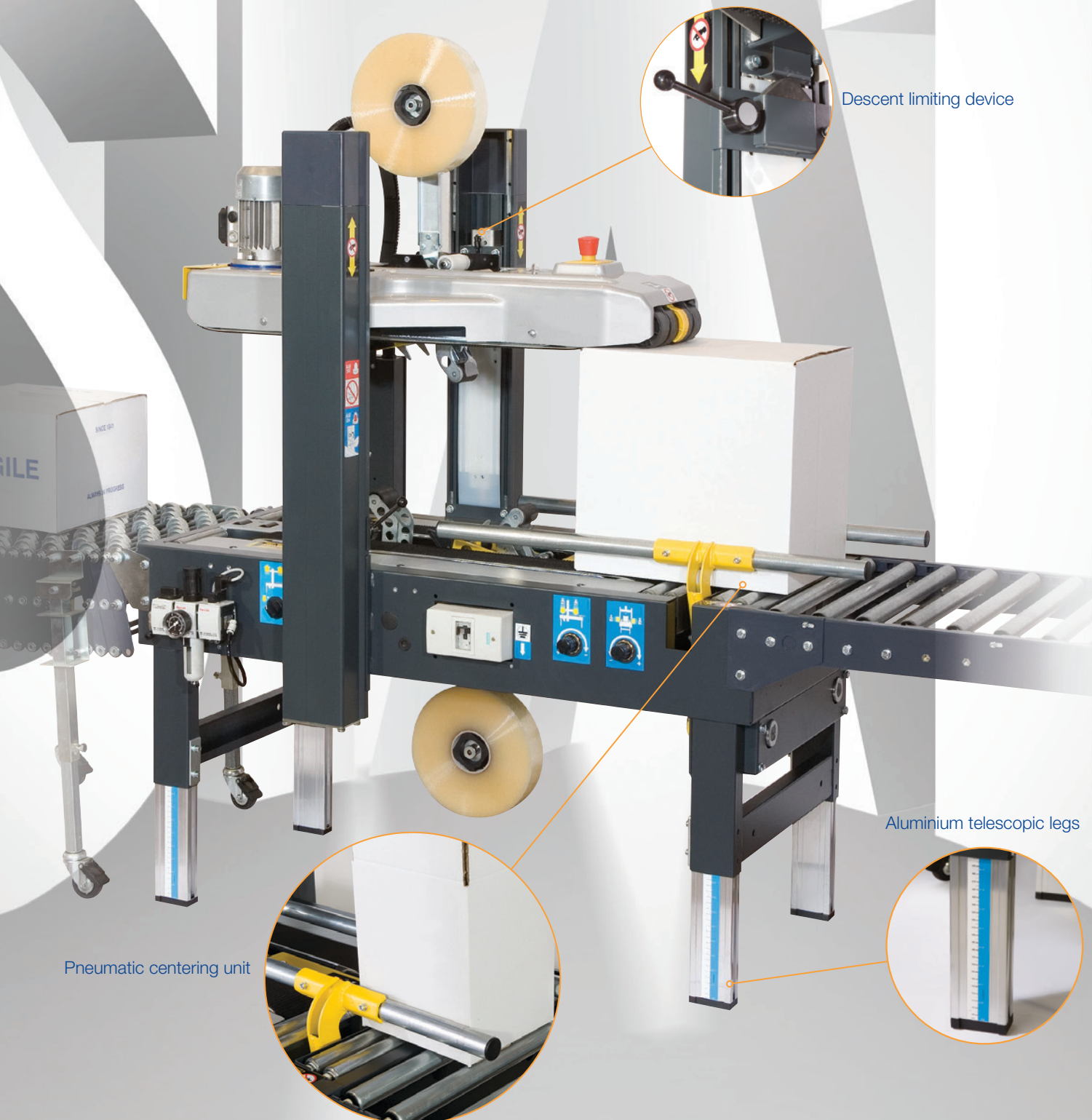

Descent limiting device

Aluminium telescopic legs

Pneumatic centering unit

CE

SR46 is a semi-automatic sealing machine with random adjustment. The machine consists of a metal structure painted with epossidic paint and columns in aluminium. The sliding plan of boxes is made up of galvanized rolls and stainless steel plate.

Working Cycle: the operator folds the top flaps and moves box forward in the machine until it is taken away by drive belts. The case sealer adjusts itself according to the box size and proceeds with the top and bottom sealing. The machine has been designed in compliance with CE regulations.



other languages: www.siat.com



> Taping units
Unità nastranti
Verschliesseinheiten
Unités enrubanneuses
Unidades de precinto

> K12R
TOP VERSION



> K12R
BOTTOM VERSION



> Machine dimensions
Dimensioni macchina
Machinemessungen
Dimensions machine
Dimensiones de máquina

Size / Weighth packaging			LxWxH
> SR46	180	225	135x105x155

> SR46

	Min.	Max
L	1395	-
W	890	-
H	1560	1900
cbh	480	800
AS 77	cbh +110	cbh +110
AS 80	cbh +160	cbh +160

> SR46

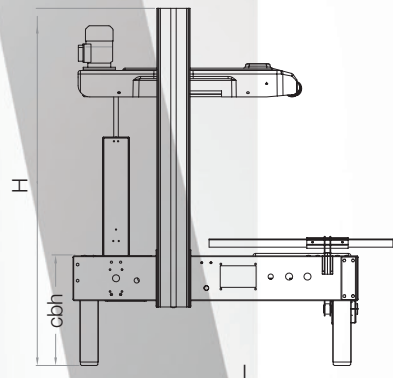

> Box dimensions
Dimensioni delle scatole
Kartonabmessungen
Dimensions des boîtes
Dimensiones de cajas

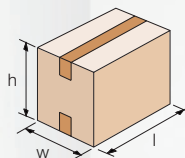

> SR46

	K12R	
	Min.	Max
l	150	∞
w	170	650
h	100	650

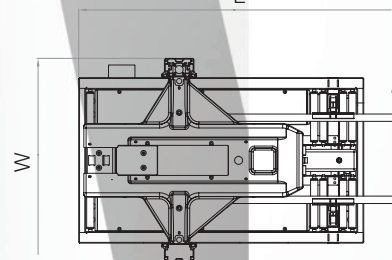

> Production capacity
Capacità di produzione
Produktionskapazität
Capacité de production
Capacidad de producción

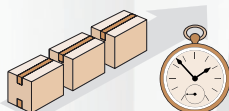

> SR46	Bph
Max pcs.*	900

* Always based on shorter manageable box

> Air consumption
Consumo aria
Druckluftverbrauch
Consommation air comprimé
Consumo de arie

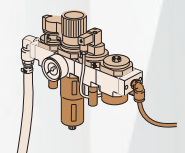

> SR46	NL.
Cycle	9

from 5,5 bar to 7 bar

> Standard voltage
Voltage standard
Standardspannung
Tension standard
Voltaje estándar

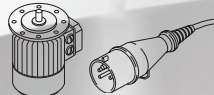

> SR46

380/400V - 50Hz - 3F	
440V - 60Hz - 3F	
Amps	1,08
Power kW	0,26
Phase	3Ph + N + PE

> Taping units
Unità nastranti
Verschliesseinheiten
Unités enrubanneuses
Unidades de precinto

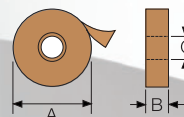

	K12R
	mm
A	410 Max
B	75
C	76

> Optionals
Accessori
Zubehör
Accessories
Accesorios

> AS80
Higher legs
Set gambe più alte
Höhere Stützen
Pieds plus hauts
Patas más altas



> AS77
Casters
Set ruote
Rädchen
Roulettes
Ruedas

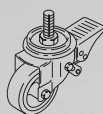

> RG
Roller conveyor
Piani a rulli
Rollenbahnen
Plans à rouleaux
Rodillos libres



> GTL - GTR
Extendable conveyor
Rulliera estensibile
Ausziehbare rollenbahnen
Convoyeur extensible
Rodillos extensibles

