

# Automatic Strapping Machine for Wide Straps

Economy model

## TP-6000

The TP-6000 is an economical model automatic strapping machine for wide straps (8mm-15.5mm). With proven quality and competitive price, it is the most cost effective solution for wide straps general purpose application.



Idépack Verpakkingmachines BV  
Zeilmaker 8  
NL-3861 SM Nijkerk  
THE NETHERLANDS  
Tel. +31(0)33 299 00 08  
www.idepack.com  
info@idepack.com

Made in Taiwan

08.2009x2000

## Economy Model TP-6000

### Main Features:

- Easy operation, simple maintenance.
- Mechanical outside tension control. Tension can be easily set with a dial.
- Affordable for every budget.

### Option

- Stainless steel frame SUS 304
- Short feed sensor  
The sensor will detect whether the strap is at sealing position. If it is not, the start switch can not be activated.

### Arch Sizes

TP-6000		650	850	1050	1250
H	W				
400			⊙		
600					
800	--				
1000	--				
1200	--				

- ⊙ Standard size: 850 mm(W) x 600 mm(H)
- means not available
- Larger arches on request

### Technical Data

Specifications	Model	TP-6000
Strap Type		P.P. strap
Strap Width		8 mm-15.5 mm
Strap Thickness		0.55 mm-0.75 mm
Strap Tension		10-70 kg
Speed (straps/minute, 60Hz)		27
Net Weight		220 kg
Power		110V, 220V, 230V, 380V, 400V 50/60Hz 1PH or 3PH

TP-6000

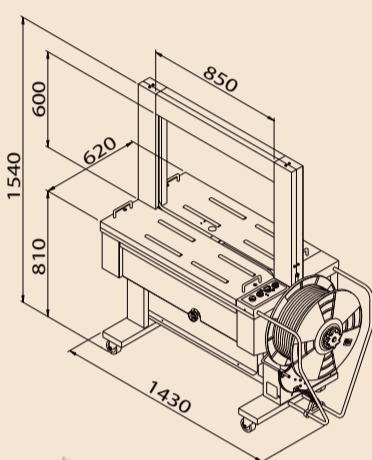

All specifications are subject to change without notice.

## TAURIS TP-601D



Transpak offers general-purpose automatic strapping machines with reliability and high performance. For wide straps application, we have the following models:

- Enhanced model automatic P.P. strapping machine Tauris TP-601D
- Enhanced model automatic P.P. strapping machine with low table Tauris TP-601L
- Enhanced model automatic PET strapping machine Tauris TP-601DPT
- Economy model automatic P.P. strapping machine TP-6000

# AUTOMATIC STRAPPING MACHINE

# Automatic Strapping Machine for Wide Straps

Enhanced model

## Tauris TP-601D Series

The Tauris TP-601D series are enhanced automatic strapping machines for wide straps. With the enhanced features, Tauris is the most powerful machine and the best price/performance ratio product in its class for wide straps general purpose application.



## Enhanced Model TP-601D

### Main Features:



#### Reliable and Robust Strapping Head

Robust mechanism design and high engineering standard ensure excellent durability of the products. Use two proximity switches to replace conventional limit switches.



#### Electronic Tension Control

Strap tension can be adjusted accurately by the simple turn of a dial. Easy operation.



#### Auto Strap Feeding

Simply insert the strap into the feeding rollers from the coil side of the machine and then push the "reset" button. The machine will automatically feed itself without the need to access to the inside of the machine. Easy strap loading.



#### Auto Strap Ejector

Loop-eject clears unwanted strap automatically if the machine is accidentally activated without a package. Eliminates downtime.

### More Features:

#### Short Feed Sensor

The sensor will detect whether the strap is at sealing position. If it is not, the start switch can not be activated.

#### Auto Strap Refeed

The machine will automatically refeed itself if a mis-feed occurs.

\* SUS 304 stainless steel frame model is on request.

#### Strap End Ejector

Ejects end of coil. Get the machine ready for the next coil of strap.

#### Methods of Cycle Initiation

The machine can be started by several methods, such as foot pedal switch, start switch, and photo eye switch.

## TP-601L

- Low-table model
- Designed to accommodate bulky or heavy packages
- Other features are the same as TP-601D



## TP-601DPT

- Suitable for PET strap
- Suitable for packages needing higher remaining holding force or stored in the place with higher temperature
- Other features are the same as TP-601D



### Arch Sizes

TP-601D/TP-601L/TP-601DPT		650	850	1050	1250
H	W				
400			⊙		
600					
800	--				
1000	--				
1200	--				

- ⊙ Standard size: 850 mm(W) x 600 mm(H)
- means not available
- Larger arches on request

### Technical Data

Specifications	Model	TP-601D	TP-601L	TP-601DPT
Strap Type		P.P. strap	P.P. strap	PET strap
Strap Width		8 mm-12 mm	8 mm-12 mm	9, 11, 12 mm
Strap Thickness		0.55-0.75 mm	0.55-0.75 mm	0.4 - 0.5 mm
Strap Tension		7-70 kg	7-70 kg	7-70 kg
Speed (straps/minute, 60Hz)		29	29	29
Net Weight		220 kg	235 kg	220 kg
Power		110V, 220V, 230V, 380V, 400V 50/60Hz 1PH or 3PH		

TP-601D/TP-601DPT

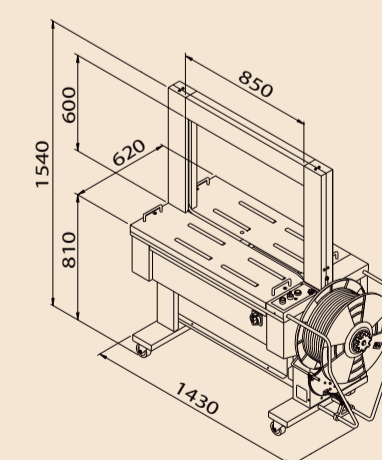

TP-601L

