



minipack® - torre
Packaging machines and systems

TUNNEL 50 TWIN GT

DUAL-CHAMBER HEAT-SHRINKING TUNNEL - PLC CONTROL - TUNNEL MOUTH
450X210 MM



DESCRIPTION

Tunnel 50 Twin GT was designed to be perfectly incorporated into the packaging machines of the Pratika range. The **Schneider Electric** electronic and electric components finally allow you to control every heat shrinking aspect. Connecting the **shrink tunnel** to the Pratika automatic packaging machine allows you to control all the parameters directly from the machine's touch screen.

With its dual heating chamber with separate adjustment and fan speed and temperature control, the exceptional thermal insulation, the high transition and shrinking speed, this tunnel is the ideal machine to provide a highly effective solution to any packaging requirement. The new plastic conveyor belt, ideal for high temperatures, guarantees greater stability for the products and less wear.



TECHNICAL FEATURES

Power supply	V	200/208/220/400
Phase	ph	3
MAX installed power	kW	14.2
MAX product dimensions	mm	(400x135 with window) / (400x200 with curtain)
Machine dimensions	mm	2170x910x1460
Machine packaging dimensions	mm	1930x980x1745
Machine weight (Net/Gross)	kg	294/352

minipack®-torre shall not be held liable for typos or printing errors in this catalogue. It also reserves the right to make changes to the specified features without prior notice. All trademarks are property of their respective owners and are hereby acknowledged.

TECHNICAL DRAWING

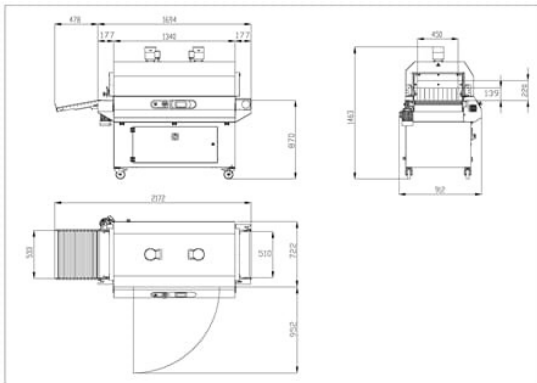

NEW TECHNICAL FEATURES

- New logic control managed by Schneider Electric TM221 PLC with 9 customisable programs
- 4.3" colour touch screen control panel
- Internal lighting for an ideal and safe view
- Transparent glass control window (exclusive patent)
- Adjustable air baffles
- Two independent chambers with separate temperature control
- Hi-tech plastic conveyor belt
- Second inverter to adjust fan motor speed
- Manually adjustable hump on conveyor belt



PERFECT INTERFACEABILITY

- Tunnel 50 Twin GT interfaces with the programs of all models of the Pratika range by means of an Ethernet cable; this allows you to set all parameters (temperature, belt speed and fan speed) from the program recalled on the packaging machine
- start/stop the operating cycle