

NASTRO-SB™ - X5 RANGE

The Next Benchmark



SEMI-AUTOMATIC CASE SEALER

100%
MADE in ITALY

NASTRO-SB™ - X5 RANGE

Nastro-SB™ X5 is a range of semi-automatic case sealing machines designed and engineered by SIAT specifically for small - medium fixed box sizes. Nastro-SB™ X5 is the ideal case sealing machine for a variety of industries like food&beverage, chemical, clothes and wine.

SPECIFICATIONS

Max Production Capacity: 1200 boxes/hour

Case type: RSC - FEFCO 0201

Max case weight: 32 kg

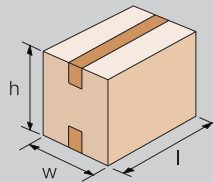

Box dimensions	L (mm)	W (mm)	H (mm)
X5S	150 - ∞	150 - 500	120 - 500
X5L	150 - ∞	105 - 500	50 - 500

KEY FEATURES

- » Seals upper & lower flaps of cardboard cases or cartons
- » Lockable electric
- » Central emergency stop to work on both sides safely
- » Best-In-Class components with SIEMENS electrics
- » Re-designed columns & upper frame to maximise strength and resist vibration
- » Quick release Taping Heads (Top & Bottom – No tools required)
- » Easy and quick belt conveyor maintenance

ENERGY SAVING VERSION

Motors and conveyors stop after a defined time when no cartons are detected



Top taping unit position
adjustment handle

Central emergency button

Top taping unit

Bottom taping unit

Easy to maintain
belt conveyor

On/off lockable switch

Belt conveyor position
adjustment handle

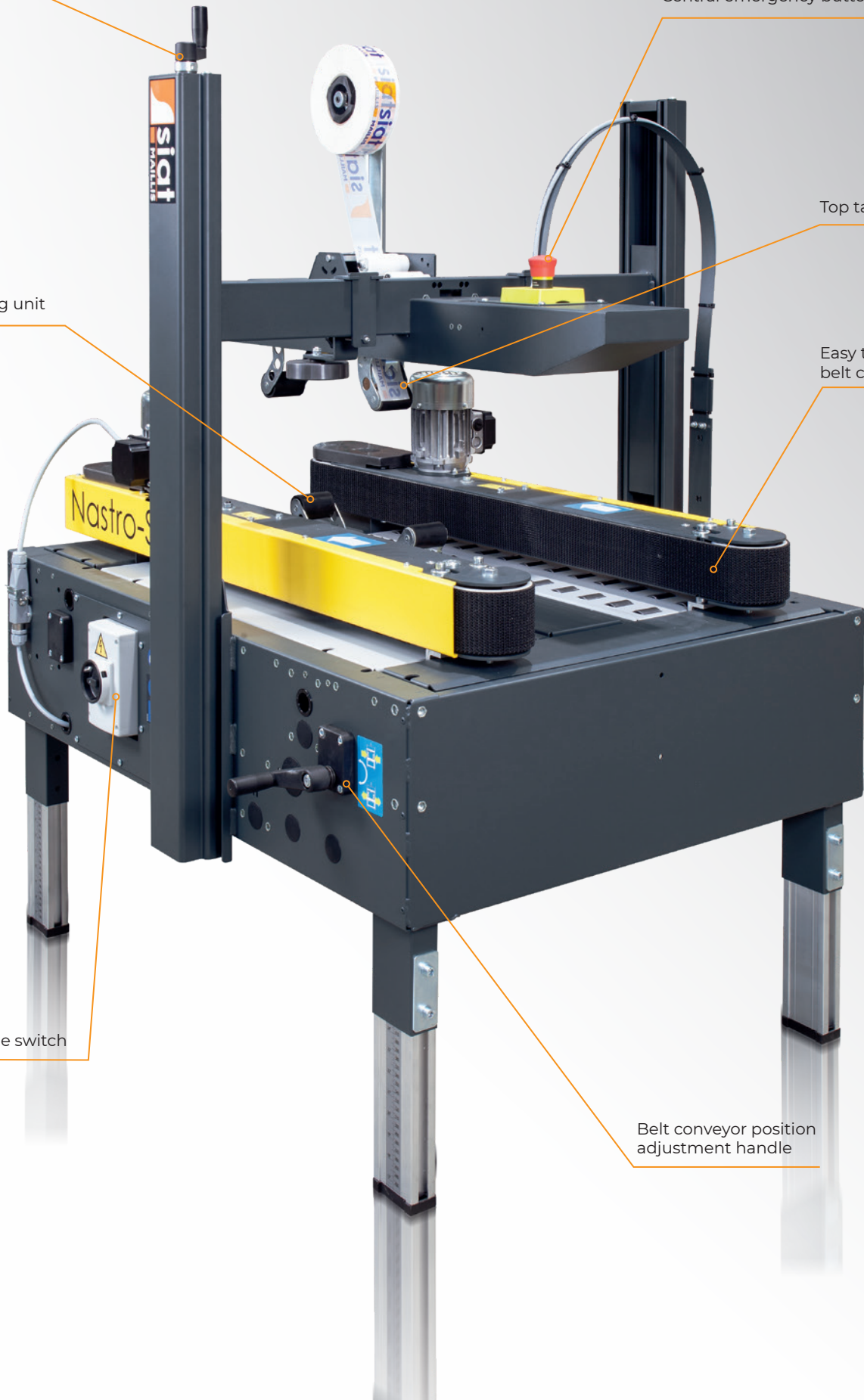

NASTRO-SB™ - X5 RANGE

Machine dimensions

Dimensioni macchina
Maschinenabmessungen
Dimensions machine
Dimensiones de máquina

	Min (mm)	Max (mm)
Total H	1275	1535
H Bench	540	800
W	950	950
W Bench	800	800
L	1100	1100

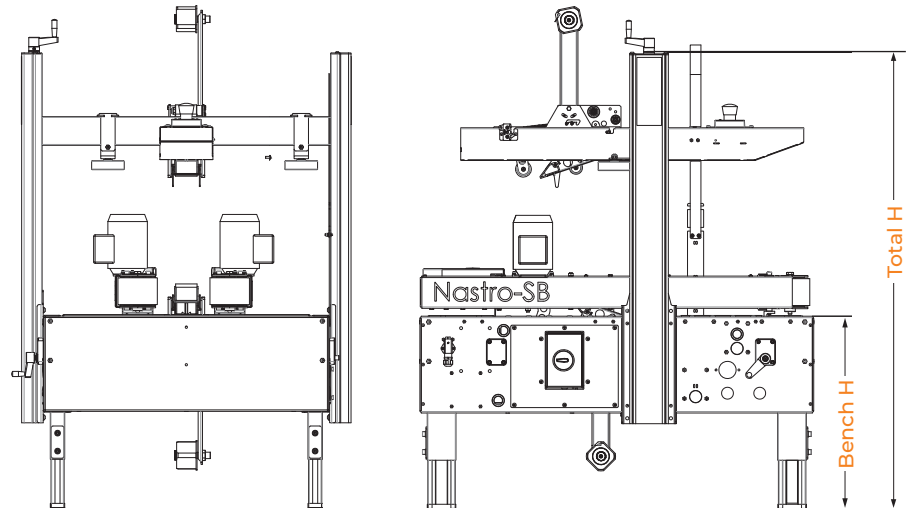

 **185 Kg**

 **220 Kg**

 **120(L) x 106(w) x 116(H) cm**

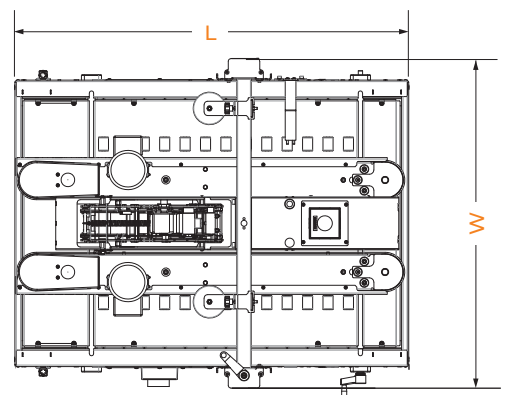

Max Production capacity

Capacità di produzione
Produktionskapazität
Capacité de production
Capacidad de producción

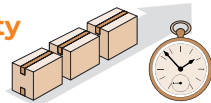

up to 1200 Bph

Standard power supply

Alimentazione standard
Standard-Stromanschluß
Alimentation électrique standard
Fuente de alimentación estándar

380/415V - 50Hz - 3ph	
440V - 60Hz - 3ph	
Amps	1,08
Power kW	0,18
Phase	3Ph + N + PE

Optional Extras

Accessori
Zubehör
Accessories
Accesorios

GTL - GTR

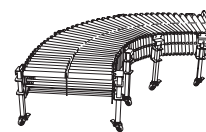

Higher Legs



Nastro legs low height (440-700 mm)
Nastro legs max height (760-1020 mm)

AS77

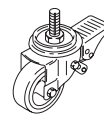

RG

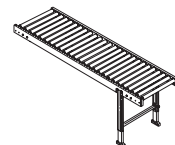

Idépack Verpakkingsmachines B.V.
Zeilmaker 8
NL-3861 SM NIJKERK
The Netherlands

Tel: +31(0)33-299 00 08
info@idepack.com
www.idepack.com

 **100%**
MADE in ITALY

SIAT S.p.A is recognised worldwide as a top-class machine manufacturer for secondary packaging and produces more than 17,000 machines per year, and has done since 1970. Our product range includes semi-automatic as well as fully automatic machines like Case Sealers and Case Erectors, Stretch Wrappers, Strapping Tools / Machines, Flexographic Printing Machines and Tape Dispensers. The company is present in more than 100 countries and is constantly investing worldwide to meet customers actual and future demands.