

MERCURY

Semi-automatic case sealer for water activated tape and adhesive tape

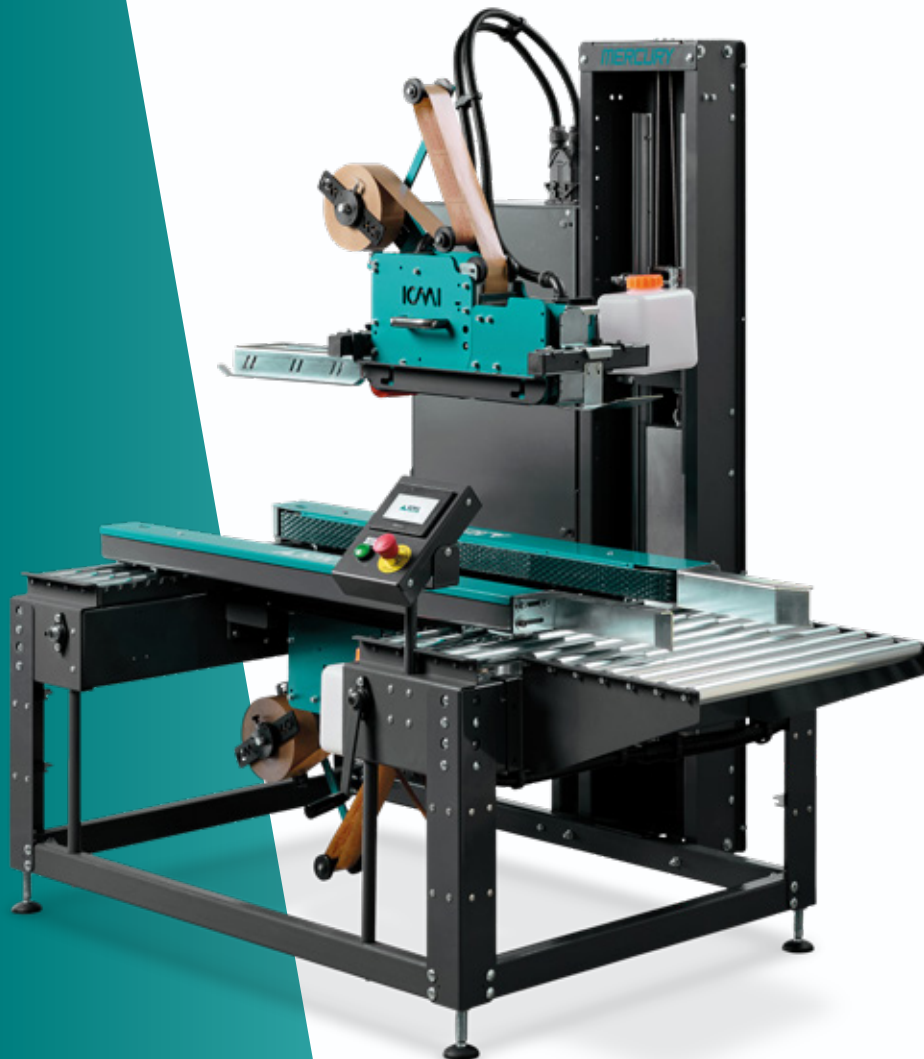

**The wise, efficient
and responsible solution
for your packaging.**

Mercury is a case sealer for water activated and adhesive tape designed for sealing a set of boxes of the same size. The adjustment to the box size is manual, simple and fast. The box is manually introduced after the upper flaps are closed by the operator. The machine automatically sticks on the tape above and below, sealing the box.

ICMI
ECO-TAPING

www.idepack.com

Idépack Verpakkingsmachines B.V. | Nijkerk - NL
Tel. +31(0)33-299 00 08 | info@idepack.com

Technical data

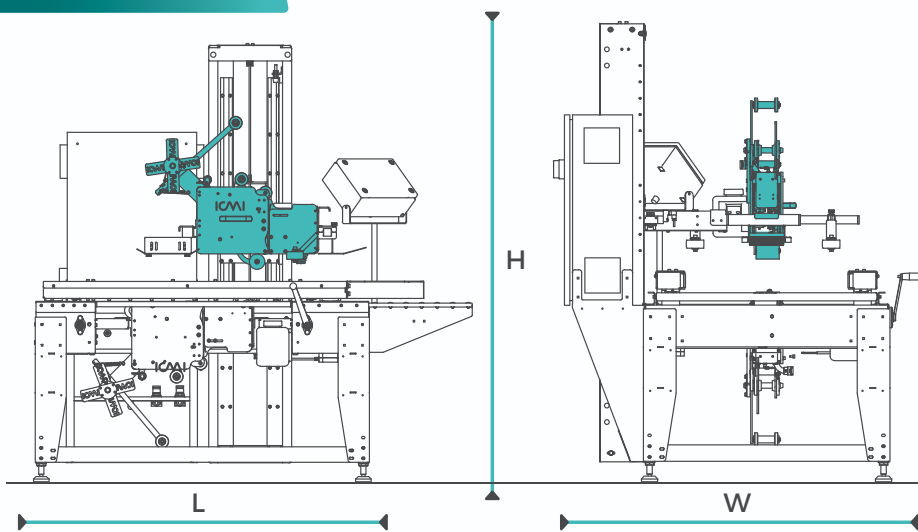

L	1686 mm
W	1065 mm
H	1860 ± 50 mm



Water-activated tape

A	From 230 mm to 400 mm*
B	From 50 mm to 70 mm
C	From 30 mm** to 70 mm

* 400 mm diameter available as optional
** 70 or 76 mm available as optional

Adhesive tape

Max. 360 mm
From 38 mm to 75 mm*
Max. 76 mm

Overlap from 50 mm to 75 mm.

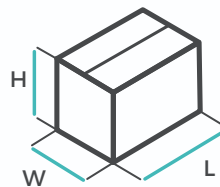

L	150 mm - ∞
W	120 mm - 600 mm
H	90 mm - 600 mm

Box sizes accepted customizable upon request

Average production

Max 14 boxes per minute*

*Box size and temperature can affect average production.

Power supply

230V P + N + PE

110VP + N + PE or 110V 2P + PE, 50/60 Hz upon request.

Electrical protection

IP 54

Weight

250 Kg

Dragging belts speed

From 200 to 400 mm/second*

*Adjustable.

Installed power

1 kW

Recommended pressure

6 bar

Air consumption

0,15 lt./cycle

Operating temperature

From 10°C to 40°C

Operating humidity

40% - 65%

NB: ICMI can fulfil requests that do not fit within the technical data sheet.

MERCURY

Semi-automatic case sealer for water activated tape and adhesive tape

Characteristics

Adjustment via hand crank on box width;

Adjustment via counterweight on box height;

Manual introduction of boxes with top flaps folded;

Box dragging, top and bottom taping simultaneous and automatic;

Water-activated tape humidification adjustable;

Water-activated tape non-return ratchet device;

Lack of inertial forces when unwinding the paper tape from the reel thanks to the pivoting roller brake;

Pneumatically controlled, self-adjusting and self-sharpening cutting units. The pneumatically controlled pressure rollers, which press the tape on the box, are adjustable for keeping constant the pressure applied on the whole box surface, allowing to work even on the softest cardboard;

Water-activated tape overlap adjustable from 60 to 75 mm;

Silent peristaltic pump located inside the taping unit that pumps water from the tank and sends it to the humidification unit.;

Energy-saving mode;

Possibility of changing the control panel side and the direction of insertion of the box;

400x580 mm infeed roller conveyor (outfeed roller conveyor upon request).

Structure

Painted iron frame;

Free roller sliding surface;

Lateral dragging belts;

All unpainted details are electro-galvanized;

Painting in RAL 7015 for fixed parts and RAL 5015 for moving parts (other RAL upon request).

Taping unit

Water-activated tape humidification and feeding units capable of using 85 g/ m² and heavy reinforced tapes without any off-standard modification. Inspection activities are easy and smooth.

All ICMI machines can be projected and manufactured upon any specific customer request. A wide range of modifications and/or accessories are available on request.

The Mercury case sealer complies with the Machinery Directive 2006/42/EC and is accompanied by a regular conformity declaration.



COMPACT

Taping unit

The **Mercury** case sealer is the first machine able to support the brand-new Compact taping units, designed and manufactured exclusively by ICMI.

The Compact unit allows an easier maintenance comparing to the standard taping head, enabling a simplified and fast reel change. In addition, Compact offers the possibility of supporting water-activated tape rolls with a minimum diameter of 250 mm, giving maximum elasticity to the customer.

Finally, the new line of ICMI case sealers capable of supporting the Compact taping unit allow the latter to be interchanged with any adhesive tape unit on the market, offering, for the first time ever, a point of contact between the world of water-activated tape and that of adhesive tape.





www.idepack.com