

CG100

Taping machine with manual regulation for gummed paper



The wise, efficient and responsible solution for your packaging.

CG100 is a taping machine for gummed paper and has been designed for taping sets of boxes of equal size. The machine receives the filled boxes coming from one or more lines via idler or powered roller beds. The spaced insertion of the boxes, the closing of the upper flaps and the sticking of the gummed paper above and below are fully automatic. Operator intervention is only required to adjust the machine to the box size.

ICMI
ECO-TAPING

www.idepack.com

Idépack Verpakkingsmachines B.V. | Nijkerk - NL
Tel. +31(0)33-299 00 08 | info@idepack.com

Technical data

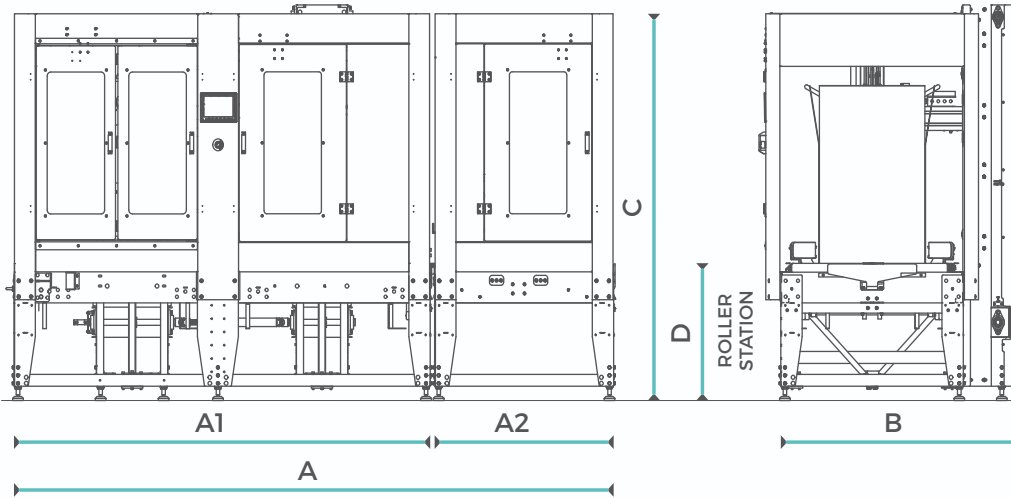

A1	2335 mm
A2	1000 mm
A	3370 mm
B	1415 mm
C	1950 ± 50 mm
D	690 ± 50 mm

(Taping machine size for boxes W 600 H 600)

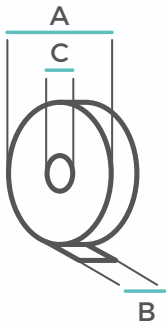

A	Max 400 mm
B	from 50mm to 80 mm
C	70 mm

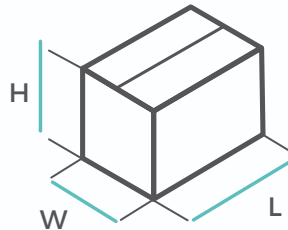

L	from 180 mm to 600 mm
W	from 145 mm to 600 mm
H	from 135 mm to 600 mm

Customizable dimensions on request

Average production



Max 8 boxes per minute*

*Box size and temperature can affect average production.

Power supply



400 V 50 Hz

Electrical protection



IP 54

Weight



820 Kg

NB: ICMI can fulfill requests that do not fit within the data sheet.

Box transfer speed



400 mm/second

*adjustable by touch screen

Installed power



2,2 kW

Pressure recommended Air consumption



6 bar

5 NI/cycle

Temperature of use



from 10°C to 40°C

Operating humidity



40% - 65%

Characteristics

Manual regulation for boxes of different sizes;

Automatic folding of upper flaps, box conveying and upper and lower sealing with a motorized introducing and spacing group for boxes;
Vertical and side auto-dimensioning with an electric control device;

Dynamic side-and-back-flap closing device with the possibility of closing boxes with horizontally opened flaps;

Boxes normally enter from the right;
entry from the left is available as an option;

Gummed paper adjustable humidification;

Gummed paper non-return ratchet device;

Lack of inertial forces when unwinding the paper tape from the reel thanks to the pivoting roller brake;

Pneumatically controlled, self-sharpening guillotine cutting group;

Rollers to press the gummed paper onto the boxes can be adjusted:
pressure can be changed depending on the contents and/or thickness of the boxes;

Front and behind can be changed from 60 to 80mm according to paper width;

Peristaltic pump that sends and draws humidification water from the tank (5 liters) to the humidification units, sending the excess back into the tank. Constant humidification of gummed paper is guaranteed even on lines with discontinuous capacity;

Humidification unit heating by cartridge heater, stainless steel, 100 W, 24 Vac, thermostat installed on the taping head and connected to the electrical panel. This is essential at temperatures below 18°C and/or medium/high output: it improves and speeds up the glue reaction of the gummed paper. The temperature can be adjusted by touch screen up to 60°/70° with sens. PT 100;

All linkages (excluding drive chains) are mounted on recirculating ball bearings;

Electrical control box made in compliance with EN-60204-1, in a box with IP65 protection level, containing the components at mains voltage and at 24V 50Hz;

Possibility of changing the box insertion direction;

Touch screen for operator data interchange.

Optional upon request

Bypass in taping process;
Customized colour;

Structure

Painted iron frame;

Upper head supported overhanging for complete freedom of action and a perfect view of the operator;

Sliding plane with idle rollers;

Box conveying with toothed side belts fitted with special section rubber blocks for secure movement of both light and delicate boxes and strong and heavy ones (30kg) (adjustable upon request);

All unpainted details are electro-galvanized;

Painting: 7015 (other colours upon request);

Accident protection consisting of painted sheet metal frames and profiles and transparent colorless polycarbonate panels. IEC337-compliant safety switches govern the spezione sliding doors. Four barriers protrude beyond the footprint in length by about 800 mm;

Taping unit/head

Patented gummed paper dispensing and wetting units capable of using 85 g/m² to heavy reinforced papers without registration. Inspection activities are easy and smooth.

All ICMI machines can be designed and built according to the customer's specific requirements. A wide range of modifications and/or accessories are available upon request.

Taping Machine CG100 complies with machine directive 2006/42/CE and is always delivered with the conformity declaration and marked "CE".





www.idepack.com